

MF18

DIGITAL TTL MACRO FLASH



INSTRUCTION MANUAL

Type C / N

NISSIN.JAPAN

Nissin

Nissin Japan Ltd., Tokyo
<http://www.nissin-japan.com>

Nissin Marketing Ltd., Hong Kong
<http://www.nissindigital.com>

Design and Specifications are subject to change without prior notice.

MF0611 REV. 1.2

Thank you for purchasing a Nissin product

Before using this flash unit, please read this instruction manual and refer your camera owner's manual carefully to get a better understanding of proper operation to enjoy flash photography.

Nissin Macro Flash MF18 is a flash system for taking close-up photos of small subjects using a flash to eliminate shadows, allowing you to enjoy photography. This instruction manual is intended mainly for Canon or Nikon digital SLR, with the latest TTL flash control system, and features Nissin's original rotating color display, easily guiding its operations.

It works automatically with Canon E-TTL / E-TTL II or Nikon i-TTL auto-flash systems. The provided adapter rings make it available for use with different lens. Please note that MF18 is not usable with other branded cameras for TTL operation.

UNIQUE FUNCTION

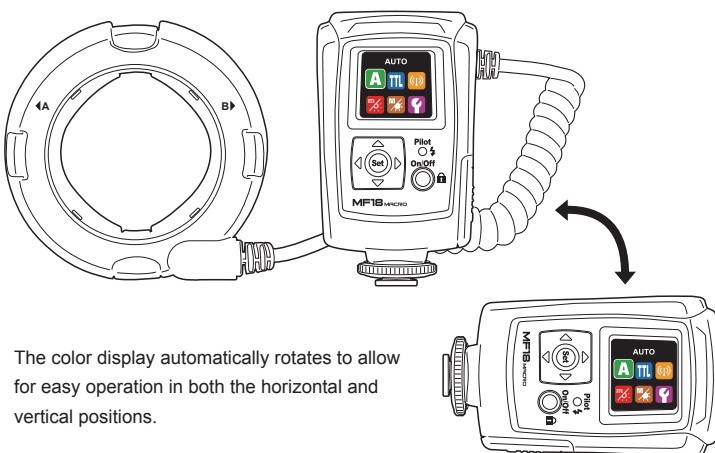

The color display automatically rotates to allow for easy operation in both the horizontal and vertical positions.

SIMPLE OPERATION

When attaching MF18 to the camera, the basic flash exposure operation is fully controlled by the camera. It is the same idea as when you use the built-in camera flash, but it is placed on the hotshoe of the camera instead of using the built-in flash.

ADVANCED FUNCTIONS

MF18 provides advanced flash functions including 1st curtain synchronization, Rear curtain synchronization and High speed shutter synchronization are supported.

Compatible cameras

Please refer Nissin's compatibility chart shown in its home page for details.
<http://www.nissin-japan.com> or <http://www.nissindigital.com/download.html>

SAFETY INSTRUCTIONS

These safety instructions refer to important information on how to use this product safely and properly. Please read the following instructions before using the product.

WARNING

This sign refers the danger or serious damage.

- The flash unit contains high voltage electric parts. Do not try to open or repair the flash unit. Return it back to the repair service station or the store you bought it from.
- Do not touch the inside parts from the opening when the unit was dropped or broken.
- Do not shoot the flash directly to the eye at short distance. It may damage the eye.
- When taking a flash picture, especially toward a baby, it is recommended to keep the flash unit at least 1 meter (3.3feet) away from the subject. Or use diffuser or bounce the light to the ceiling or to the wall to soften its intensity.
- Do not place the flash unit near any flammable gas, chemical or such liquids. It may cause fire or electric shock.
- Do not touch the flash unit with wet hands or use in the water. The flash unit carries high voltage inside and it may cause an electric shock.
- Do not shoot the flash unit directly at the driver of automobiles or such vehicles.
- Do not set the flash window close to the human body and shoot, which may get burned.
- Place the batteries correctly in position. Placing the batteries in wrong polarity may cause leakage, exothermic heat or explosion.

CAUTIONS

This sign refers the damage or defect.

- Do not leave or store the flash unit in the temperature over 40°C, such as in the automobile.
- The flash unit is not water resistance. Keep the unit away from rain, snow and humidity.
- Do not use benzene, thinner or other alcoholic agents to clean the unit.
- Do not use this flash unit with the cameras which are not recommended in compatibility list at official website, otherwise it may damage the camera's circuitry.
- Remove the batteries when not in use for a longer period of time.
- Do not have a heavy impact to the flash unit, nor throw it onto a hard surface floor.
- When using the external power pack, read the safety instructions carefully and follow the operation manual.

Nomenclature

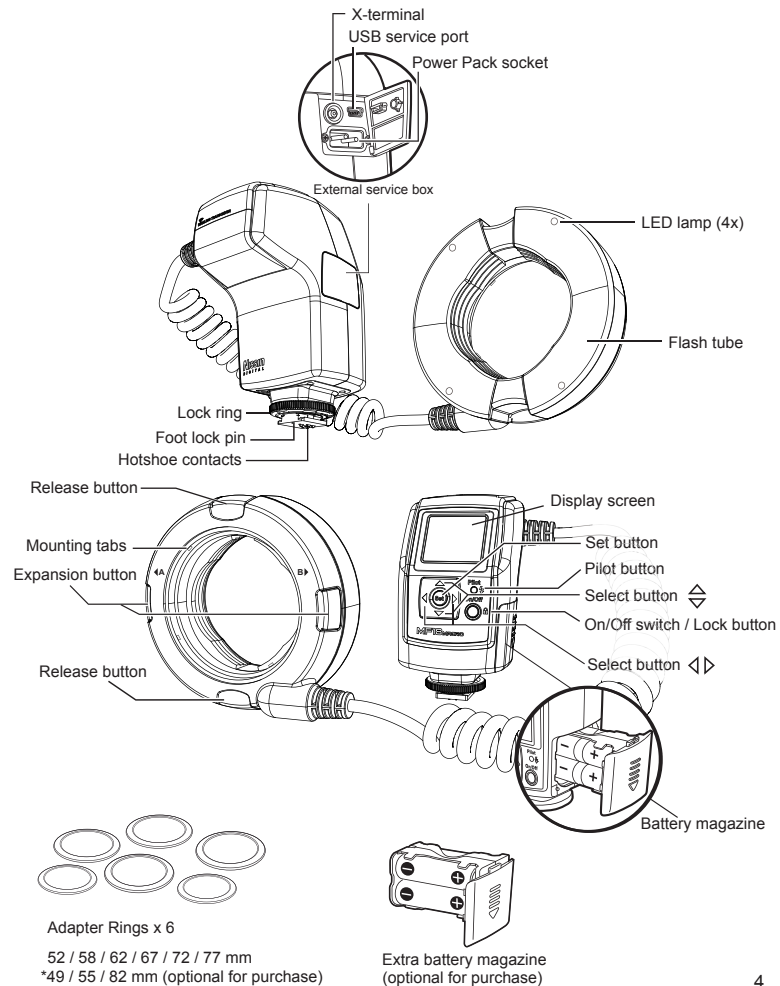

MENU SCREEN FOR MAIN MODES

MF18 Flash Modes and Functions - to be set on the flash unit.



- A** ... Full Automatic Mode
- TTL** ... TTL Program Mode
- (P)** ... Wireless Mode (Master)
- m** ... Fine Macro Mode
- M** ... Manual Mode
- Y** ... Custom Setting Mode

- A** Full Automatic Mode _____ page 11
Flash light is fully controlled by the camera for the most proper exposure.
- TTL** TTL Program Mode _____ page 13
Flash light is automatically controlled by the camera but the flash exposure value can be compensated.
- (P)** Wireless Mode (Master) _____ page 15
Master Mode - Selecting the desired manual power on the ring flash (Group A and B) and controlling the slave flashes (Group A or C).
- m** Fine Macro Mode _____ page 18
Setting the flash power from 1/128 to 1/1024 with 1/6 Ev steps.
- M** Manual Flash Mode _____ page 19
Setting the flash power from 1/1 (Full) to 1/64 with 1/3 Ev steps.
- Y** Custom Setting Mode _____ page 20
Variety of custom settings is available for own default value.

ADVANCED FUNCTIONS

For Canon: Functions by Flash setting

- FE. Lock** FE. Lock _____ page 21
Flash exposure can be locked at the main subject while moving the framing.
- 1st curtain synchronization** _____ page 22
The flash fires immediately after the first curtain has fully opened.
- High speed shutter synchronization** _____ page 22
Flash synchronizes to the faster shutter speed than regular synchronization speed.
- Rear curtain synchronization** _____ page 23
The flash fires just before the rear curtain closes. A moving subject will appear with such moving marks behind.

For Nikon: Functions by Camera setting

- Fv. Lock** Fv. Lock _____ page 21
Flash exposure can be locked at the main subject while moving the framing.
- 1st curtain synchronization** _____ page 23
The flash fires immediately after the first curtain has fully opened.
- High speed shutter synchronization (FP)** _____ page 23
Flash synchronizes to the faster shutter speed than regular synchronization speed.
- Rear curtain synchronization** _____ page 23
The flash fires just before the rear curtain closes. A moving subject will appear with such moving marks behind.

BASIC OPERATION

Inserting batteries

Usable batteries - Alkaline batteries, Lithium batteries, NiMH batteries.

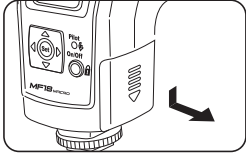

1. Remove the battery magazine and insert 4 x size AA batteries as shown in the picture.
2. The battery magazine is specially designed so that every battery is placed in the same direction to avoid the confusion in poor light condition.
3. +/- symbol is clearly marked at the battery compartment.
4. Place the battery magazine back into the body.

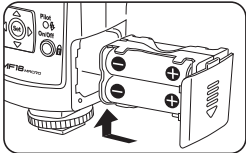
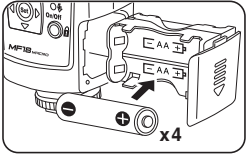

When the recycle time becomes longer than 20 seconds, replace the batteries with fresh ones or recharge the batteries (rechargeable batteries).

NOTE

It is recommended to use all 4 batteries in same brand and type, and replace them all at the same time.
Wrong insertion of each cell would not make electric contact.

Mounting MF18 on the Camera

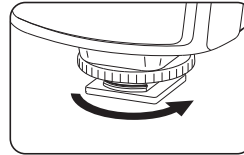

1. Turn off the power switch of both MF18 and the camera

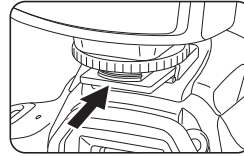

2. Loosen the lock ring of MF18 so the hotshoe mounts easily.

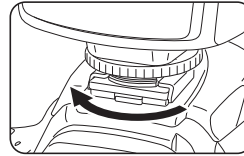

3. Slide the mounting foot of MF18 into the hotshoe of the camera from the back.

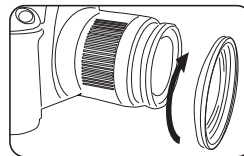

4. Turn the lock ring to opposite direction and tighten it.

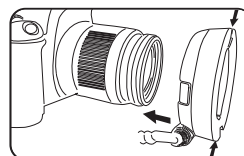

5. Screw the adapter ring that is the same size as the lens onto the front thread of the lens.



6. Attach the flash head to the adapter. Press the release buttons on top and bottom of the flash head to insert the four mounting tabs on the inside of the flash head correctly into the groove on the adapter ring.

7. After the flash head is attached, pull it lightly to make sure the tabs are inserted into the groove correctly.

Expansion of the Flash Head

After the flash head has been attached, should you experience vignetting due to the flash covering a part of the lens, it is recommended that the flash ring be expanded to its wide position. This should eliminate the dark corners on the image. (It is also depending on the angle of view).

Remark: This Macro flash is preferable to apply on macro lens. For zoom lens, please adjust the suitable position to prevent the dark corners.

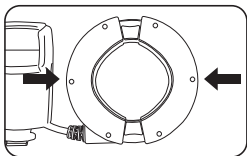

1. Press the expansion buttons on the sides of flash head.
2. The flash head is expanded. It is possible to expand one side if necessary.

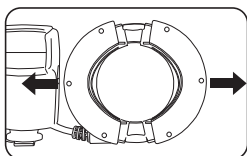

3. To close the expansion, push it lightly back to the original position.

Removing MF18 from the Camera

- Loosen the lock ring and slide the mounting foot of MF18 off the hotshoe of the camera. Make sure to turn the lock ring all the way to completely clear the lock pin off the hooking slot on the hotshoe. Press the release button on the flash head and remove. Screw the adapter ring off the front thread of the lens.

Turn on the flash unit

- Press the on/off switch. Main screen appears.
- The pilot lamp blinks red showing the unit is charging.
- In a few seconds, the pilot lamp turns green.
- The display screen automatically turns off in about 30 seconds after the setting job is terminated.
- For a test-flash, press the pilot lamp.
- To turn off the flash unit manually, press the on/off switch and hold it for 2 seconds.

Modeling LED lamps function

The modeling LED lamps with light ratio control, makes it easy to focus on the shooting subject. The brightness reflects flash power ratio setting of side A and B; therefore, the desired effect can be previewed.

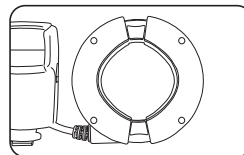

1. To switch on the modeling LED lamps, press set for 2 seconds.

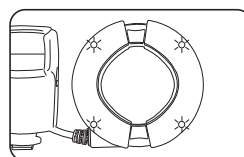

2. The LED lamps switch off temporarily when the flash fires, then switch on again for the next shoot. The icon is indicated on the screen.
3. To switch off the modeling LED lamps, press set for 2 seconds.

MF 18 has energy saving double power off function.

1. The power is automatically turned off (to stand-by mode), in about 30 seconds of idle use on the camera or after the last setting is made. To save the battery energy, you can select the display-off setting from the custom setting. In this case, the display screen turns off in about 8 seconds of idle use.
While MF18 is in the stand-by mode, display screen turns off and the pilot lamp blinks every 2 seconds showing the flash unit is in stand-by mode.
To turn on MF18 again, press the camera's shutter button halfway or press any button of the flash unit.
2. In case the MF18 is not in use over 30 minutes, the unit is completely turned off. To turn on MF18 again, take the first step of turning the flash unit on.
The mode and the value set on the flash unit before turning off is memorized and returns in the same condition when switched on again.





SETTING THE MODE AND THE FUNCTION

A Full Automatic Flash Control

The modes to be set on the camera (For Canon):

[] (Full Auto), [**P**] (Program), [**Tv**] (Shutter priority),

[**Av**] (Aperture priority), [**M**] (Manual), [**A-DEP**] Automatic depth-of-field,





 Portrait,  Landscape,  Close-up,  Sports,

 Night Portrait.

The modes to be set on the camera (For Nikon):

[] (Full Auto), [**P**] (Program), [**S**] (Shutter priority),

[**A**] (Aperture priority), [**M**] (Manual),

 Night,  Macro,  Sport,  Kids,

 Scene,  Portrait



In all those camera's modes listed above, MF18 will automatically and fully work in E-TTL / iTTL automatic flash control system.

- Set MF18 to the camera's hotshoe and press the on / off switch to power on.
- Display screen automatically shows the Full Automatic Mode.
- MF18 is now set for the camera's automatic flash control system.
- Press the on/off switch once again to lock this condition on your flash. (Press it again to release the lock)
- All the jobs required for this mode are completed.
- To switch on the modeling LED, press **Set** for 2 seconds until the modeling LED icon () is on. The icon switches off temporarily when fires or press the **Set** button for 2 seconds to switch off.



- When the pilot lamp turns green, press the shutter button of your camera halfway to focus the subject.
- Shutter speed, aperture and flash mark () are shown in camera's view finder and the display panel of the camera.
- Press the shutter, and MF18 is fired. The result is immediately shown on the camera's LCD monitor.
- Flash power is automatically controlled by the camera and the most proper exposure is obtained on your picture. The flash power of Side A and B are equal.

MF18 is a supplement to help you in taking creative and live picture. While you are taking pictures in Full Automatic mode, almost all jobs are automatically done by the camera and you just control the camera only.

Mode		Shutter Speed	Aperture Setting	Control on the camera
Canon	Nikon			
[]	[]	Automatic	Automatic	Automatic
[P]	[P]	Automatic	Automatic	Automatic
[Tv]	[S]	Manual	Automatic	Any available shutter speed can be set.
[Av]	[A]	Automatic	Manual	Any available f-stop can be set.
[M]	[M]	Manual	Manual	Any shutter speed / f-stop combination can be set.





TTL TTL Flash Exposure Value Compensation

With the latest TTL flash control system, the flash power level is always automatically controlled by the camera for the most appropriate exposure. You can soften or weaken the flash light, or give more light to the subject without changing the environmental or background exposure effect

The modes to be set on the camera (For Canon):

[] (Full Auto), [**P**] (Program), [**Tv**] (Shutter priority),

[**Av**] (Aperture priority), [**M**] (Manual), [**A-DEP**] Automatic depth-of-field,





 Portrait,  Landscape,  Close-up,  Sports,



 Night Portrait.

The modes to be set on the camera (For Nikon):

[] (Full Auto), [**P**] (Program), [**S**] (Shutter priority),

[**A**] (Aperture priority), [**M**] (Manual),





 Night,  Macro,  Sport,  Kids,

 Scene,  Portrait, depending on the camera model.

In all those camera's modes listed above, MF18 will automatically and fully work in E-TTL / iTTL automatic flash control system.

- Set MF18 to the camera's hotshoe and attach the flash head to the lens with suitable adapter ring. Press the on / off switch to power on.
- Display screen shows A. Press **Set** and the display turns to the screen of 6 icons (main menu).
- Select TTL by select button  and set **Set**. Or the display returns back to the Auto mode screen in about 8 seconds.



- The TTL flash exposure compensation value 0.0Ev is shown as a default setting.
- TTL flash exposure compensation is provided in 19 steps by 0.3 Ev increment from -3.0 · · · 0 · · · +3.0 Ev.
- Select   the EV compensation value you desire.
- To set the power ratio of side A (left) and B (right), select  the ratio. The power level ratio can be selected from 15 different combinations with 0.5 Ev steps, A:B = 1:--- (flash off) – 8:1 – 5.6:1 – 4:1 – 2.8:1 – 2:1 – 1.4:1 – 1:1 – 1:1.4 – 1:2 – 1:2.8 – 1:4 – 1:5.6 – 1:8 – --- (flash off):1.
- To switch on the modeling LED, press **Set** for 2 seconds until the modeling LED icon () is on. The icon switches off temporarily when the flash fires or press the **Set** button for 2 seconds to switch off. The power level ratio of modeling LED can be selected from 15 different combinations.
- To keep this value on your flash, press on / off switch to lock. (Press it again to release the lock)
- Take a picture and the aimed subject is shown with required lighting effect by keeping the exposure level of background as originally expected.
- On some cameras, the TTL flash exposure compensation can be set on the camera.
- When the flash exposure compensation is set on the flash unit, this value is to be counted in addition to the compensation value you set on the camera.
- The display screen of the flash unit however shows the exposure compensation value set on the flash unit only.

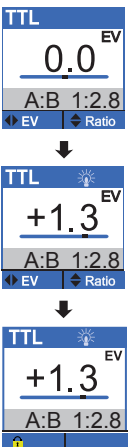



Wireless Mode (Master)

The modes to be set on the camera (For Canon):

[**Q**] (Full Auto), [**P**] (Program), [**Tv**] (Shutter priority),

[**Av**] (Aperture priority), [**M**] (Manual), [**A-DEP**] Automatic depth-of-field,

The modes to be set on the camera (For Nikon):

[**AUTO**] (Full Auto), [**P**] (Program), [**S**] (Shutter priority),

[**A**] (Aperture priority), [**M**] (Manual),

MF18 provides wireless Master / Remote (slave) wireless flash system.

The Ring flash placed on the camera is called "Master"- Group A and B.

The flash unit placed off the camera is called "Remote (Slave) Flash". Multiple number of flashes can be set and controlled in Groups A or C; 4 channels are prepared for signal transmission between the Master flash and the Remote(Slave) flash.

Available combination of flash models and cameras

Wireless TTL Flash Pairing Chart

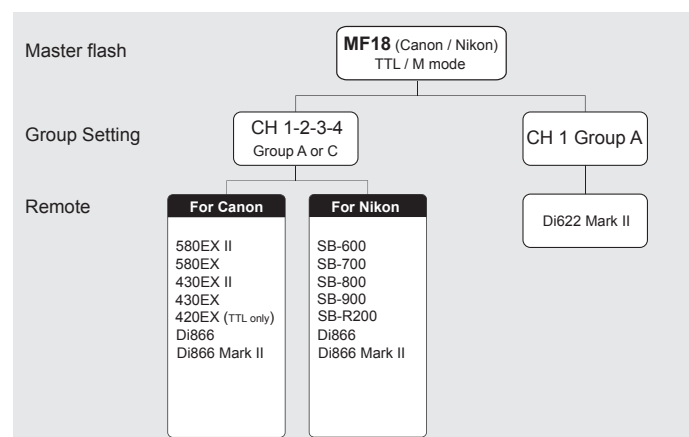

In the main page

Navigate the cursor and adjust the value according to the instruction at the bottom bar.

◀▶ **Cursor Navigation**

◀▶ **Value Adjust**

Channel Select

Select Channel: Ch1, Ch2, Ch3 & Ch4

+/- EV (EV compensation)

EV compensation at TTL mode can be selected from -3.0 Ev to +3.0 Ev with 1/3 Ev steps.

Group Setting

Group

A = Left flash

B = Right flash

C = Remote flash

A	TTL	0.0
B	TTL(A:B)	1:1
C	TTL	0.0

Flash Mode

TTL = TTL Mode

M = Manual Mode

Value Adjustment

Ev compensation at TTL mode (-3.0Ev to +3.0Ev)

Power Ratio at TTL mode

(---:1, 1:8, 1:5.6, 1:4, 1:2.8, 1:2, 1:1.4, 1:1, 1.4:1, 2:1, 2.8:1, 4:1, 5.6:1, 8:1, 1: ---)

Power Ratio at M mode

(---, 1/128, 1/100, 1/80, 1/64, 1/50, 1/40, 1/32, 1/25, 1/20, 1/16, 1/13, 1/10, 1/8, 1/6.4, 1/5, 1/4, 1/3.2, 1/2.5, 1/2, 1/1.7, 1/1.3, 1/1)

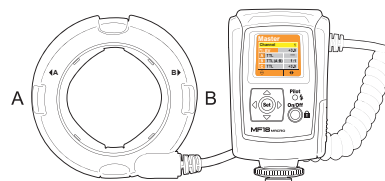

The flash unit has two modes for adjusting the amount of light produced by the flash: An automatic mode (TTL mode) and Manual mode (M Mode).

Selecting TTL

1. Select the Channel from Ch1 to Ch4.
2. Navigate the cursor to **Group A** and set **TTL**. Adjust and set the EV compensation level from -3.0Ev to +3.0Ev.
3. When **Group A** is set **TTL**, **Group B** is automatically set to **TTL (A:B)**. Navigate the cursor to **Group B** and set the ratio of A:B from --- (flash off):1 to 1: --- (flash off) with 0.5 Ev steps.
4. For the remote flash, navigate the cursor to **Group C**. Adjust and set the EV compensation level of **Group C** from -3.0Ev to +3.0Ev.

Master		
Channel		1
+/- EV		+3.0
A	TTL	---
B	TTL(A:B)	1:1
C	TTL	+3.0

Selecting Manual (M)

1. Select the Channel from Ch1 to Ch4.
2. Navigate the cursor to the **Group A** and set **Manual**. Adjust and set the power ratio from --- to 1/1.
3. When **Group A** is set **Manual**, **Group B** is automatically set to **Manual**. Navigate the cursor to **Group B** and set the power ratio from --- (flash off) to 1/1 with 1/3 Ev steps.
4. For the remote flash, navigate the cursor to **Group C**. Adjust and set the power ratio from 1/128 to 1/1.

Master		
Channel		1
+/- EV		---
A	M	1/128
B	M	1/128
C	M	1/16

*Remark: Setting Group C in Master flash can also control the slave flash with wireless remote setting in Group A or C.



Fine Macro Mode

The Fine Macro mode provides the setting of power ratio from 1/128 to 1/1024 with 1/6 EV steps. (*Remark: Fine Macro mode is not available for all shutter functions)

◀▶ **Cursor navigation**

◀▶ **Value adjustment**

- Select Fine Macro in main menu, press set **Set**.
- To set the desired power ratio of both Side A and B, navigate the cursor **◀▶** to adjust the power ratio **OR** To set the desired power ratio of either Side A or B, navigate the cursor **◀▶** to select and set the power ratio individually.
- The power ratio can be selected from 1/128 to 1/1024 with 1/6 EV steps.
- To switch on the modeling LED, press **Set** for 2 seconds until the modeling LED icon (💡) is on. The icon switches off automatically after fired or press the **Set** button for 2 seconds to switch off.

Fine Macro	
1/512	1/512
-1/6ev	-1/6ev
Side A	Side B

Fine Macro	
1/128	1/512
-0ev	-1/6ev
Side A	Side B



Manual Mode

The Manual mode provides the setting of power ratio from 1/1 (full) to 1/64-2/3EV or OFF (Side A or B) with 1/3 EV steps.

Cursor navigation Value adjustment

- Select Manual in main menu, press set **Set**.
- To set the desired power ratio of both Side A and B, navigate the cursor \blacktriangle to adjust the power ratio **OR** To set the desired power ratio of either Side A or B, navigate the cursor \blacktriangle to select and set the power ratio individually.
- The power ratio can be selected from 1/1 to 1/64 (or OFF) with 1/3 EV steps.
- To switch on the modeling LED, press **Set** for 2 seconds until the modeling LED icon (🔦) is on. The icon switches off automatically after fired or press the **Set** button for 2 seconds to switch off.

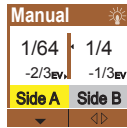
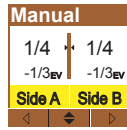

Custom settings

A variety of custom settings enable you to customize your MF18.

- Press Set **Set** to enter the Custom setting page.
- Select \blacktriangle the item to be customized and set \blacktriangle the value to customize.
- 6 custom settings are prepared.

My TTL TTL Exposure level custom setting

TTL exposure level is accurately calibrated for standard balance in accordance with Nissin's standard. If any adjustment is however required, or if you like to set your own preferable level, it can be adjusted for about ± 3 EV. by every 1/3 steps.

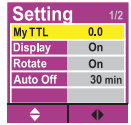

Display Display can be set off if it's not necessary.

To save battery energy, or imply to avoid the display illumination, the display screen can be switched off when not in operation. Set it off, and the display goes off in 8 seconds after the last operation. The display will not be woken up by the camera's shutter release. The display can only be woken up by the operation button of MF18.

Rotate Cancel the rotating action and keep the image fixed. The screen won't rotate.

Auto Off Auto off timing can be selected from 10min, 15min, 30min, 45min, 60min or off (cancel).

Shutter For Canon only Shutter functions can be selected from 1st Curtain synchronization, High Speed synchronization and Rear curtain synchronization.

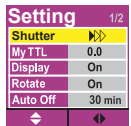
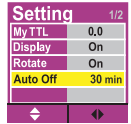

Firmware A firmware upgrade service is available for the MF18 which provides a USB service terminal (By local service/ local dealer) to upload the latest software.

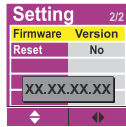

Reset All the custom settings are reset to the default values and conditions which are provided and set at the factory.

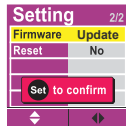

- Those customized value and conditions are effective on all modes and memorized even when the flash unit is switched off.
- To reset the customized value or conditions, select **Reset**, choose "Yes" and set **Set**. All the memorized data is cancelled and MF18 is reset to the default value and condition.

Other shutter functions by camera setting

For Canon cameras

FE Lock MF18 offers this function at TTL mode. Focus the main subject and press $\langle * \rangle$ button on the camera (or $\langle FEL \rangle$ button on some cameras. Exposure value on the main subject is memorized in the flash. Aim the viewfinder center over the main subject and release the shutter.

For Nikon cameras

FV Lock MF18 offers this function at TTL mode. Default the Fn button to FV lock. Press the Fn button to lock flash value. Press again to cancel Fv lock. Exposure value on the main subject is memorized in the flash. Aim the viewfinder center over the main subject and release the shutter.

ADVANCED CUSTOM SETTING

An ADVANCED CUSTOM SETTING enables you to enjoy creative flash photography. For advanced flash photography, the following functions can be set on your flash or camera according to the camera model.

For Canon (Shutter functions setting by flash)

1st curtain synchronization

Usually, the flash fires immediately after the first curtain has fully opened. This is called 1st curtain. This method is usually used during flash shooting.

- Return to the main menu, press set **Set**. Select SETTING and press set **Set**.
- Navigate the cursor to Shutter and select $\blacktriangleright\blacktriangleright$, then press set **Set**.
- Set the EV compensation value and power ratio level you desire.

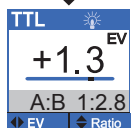
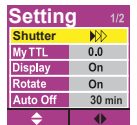

High speed shutter synchronization

MF18 synchronizes to the highest shutter speed set on the camera. To capture subject with softening off the back ground in daylight synchronization photography, the shutter speed is to set at higher than the regular synchronization speed.

- Return to the main menu, press set **Set**. Select SETTING and press set **Set**.
- Navigate the cursor to Shutter and select H , then press set **Set**.
- Select TTL in the main menu, the High speed synchronization icon (H) switches on.
- Set the EV compensation value and power ratio level you desire.

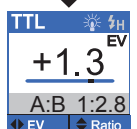
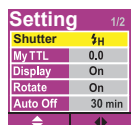

Rear curtain synchronization

In rear-curtain sync., the flash fires just before the rear curtain closes. By using this function at slow shutter speeds, a moving subject will appear with moving marks behind. Refer to the operation manual of the camera for details.

- Return to the main menu, press set **Set**. Select SETTING and press set **Set**.
- Navigate the cursor to Shutter and select **Shutter**, then press set **Set**.
- Select TTL in the main menu, the Rear curtain synchronization icon (**Shutter**) switches on.
- Set the EV compensation value and power ratio level you desire.

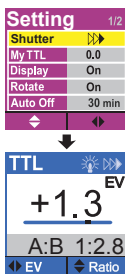

For Nikon (Shutter functions setting by camera)

For Nikon cameras, the shutter functions need to be set at the camera and the icon indicates the current setting.

- Select the TTL in the main menu and press set **Set**.
- Set the shutter function in the camera.
- The shutter function is shown.
- Set the EV compensation value and power ratio level you desire.

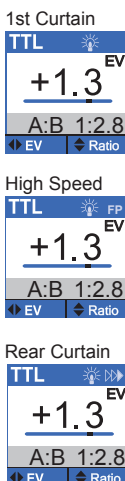

OTHER FEATURES

External Power Pack Socket

When using an external power source, the number of flashes is increased and the recycling time is shortened. The following external power pack is available in option.



MF18 is

automatically turned off when repeating flash continuously over 20 to 30 times

Battery = NiMH battery	Operation Modes	Recycle time
Nissin Power Pack PS 300	500 flashes	0.7 sec.
Nikon SD-8A / SD-9	200 flashes	1.5 sec.
Canon CP-E4	260 flashes	1.5 sec.

to protect the flash circuitry. It will be automatically reset after 15 minutes of inactivity. Please note that the basic operation is controlled by the main batteries (battery magazine) in the flash unit and when the main batteries are exhausted, the flash control system does not work. Replace the batteries when recycle time becomes longer than 20 seconds by main batteries only.

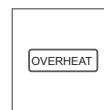

USB Service Port

Tired of your flash no longer working whenever a new camera comes onto the market? A firmware upgrade service is available for the MF18, which provides a service terminal to upload the latest software. A service charge for the firmware upgrade will be applied, varying with different region. Please check at your local dealer for details about the update service.

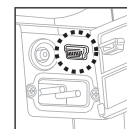

X terminal

MF18 has x-terminal contact to support a flash synchronization. The external flash can be triggered by the MF18 through X terminal. A standard sync-cable in the market is usable.

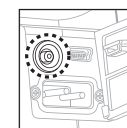

Guide Number table

Guide No. at manual exposure mode (ISO 100 in meters)

Flash Power Level

Full	1/2	1/4	1/8	1/16	1/32	1/64	1/128
16	11.31	8	5.66	4	2.83	2	1.41

Remarks: Please be aware that calculating the f-number by dividing the guide number by the distance will not result in correct f-numbers when the distance is shorter than approx. 1 meter. This calculation requires that the size of the light source is very small compared with the distance. This condition is not met at short distances. Therefore we recommend to use the TTL mode at short distances instead of manual mode with calculation of the f-number.

TROUBLE SHOOTING

The flash unit does not start charging.

- Batteries are not correctly installed
>>> Re-install batteries to correct problem.
- Batteries are exhausted
>>> Replace the batteries if the recycle time is beyond 20 seconds

The flash unit does not flash.

- The flash unit is not firmly clipped on the camera
>>> Mount the flash unit firmly on the camera's hot shoe.
- The flash unit is automatically powered off
>>> Turn on the switch again.

The flash picture is overexposed or underexposed.

- There is a reflective object or strong lighting near the subject.
>>> Use Fv lock FE lock
- The unit is set for manual exposure mode at wrong distance
>>> Set to TTL mode or select other power level.

SPECIFICATIONS

Usable cameras	Canon E TTL / Nikon iTTL flash system SLR and hotshoe type Compact digital cameras-ref. Nissin official website for camera models.
Guide No.	16 / 53 (ISO 100 m/ft)
Flash energy	83 Ws at full power
Illumination coverage	80° vertical, 80° horizontal
Power source	Four size-AA Alkaline / Ni-MH / lithium batteries
Battery life (Approx. flash count)	120-800 flashes (with size-AA alkaline batteries)
Energy Saving	Factory setting :Stand-by mode in 30 seconds, Power off in 30 minutes Custom setting: 10min, 15min, 30min, 45min, 60min or off (cancel)
Recycle time	0.1 ~ 5.5 seconds with Alkaline / NiMH batteries
Color Temperature	5600 K at full power flash
Flash Duration	1/700 seconds at full power (When A and B tube flash together) 1/300 seconds at full power flash (When A or B tube flash individually) 1/700-1/30,000 seconds (When A and B tube flash together) FP flash for high speed synchronization
Wireless flash	Optical pulse 4 channels Transmission angle approx. 80° top / bottom 80° left / right Controllable slave group: Group A / Group C
Lens adapter range	49 - 82mm (52 / 58 / 62 / 67 / 72 / 77 mm are included) * 49 / 55 / 82 mm are optional for purchase
External Power Pack	Service socket for the external power pack(optional accessory) Nissin Power Pack PS300 Canon Power Assist Pack CP-E4 Nikon Power Assist Pack SD-8A and SD-9
USB service port	For firmware update service USB cord is not included
Sync. Contact	Camera's hot shoe i-TTL for Nikon / E TTL for Canon system Traditional sync. System X-terminal socket
Dimensions	Main body: 115 x 65 x 85mm (4.5 x 2.6 x 3.3 inch) Ring flash: 120 x 134 x 41mm (4.7 x 5.3 x 1.6 inch)
Weight	446 g (15.7oz) w/o battery

WARRANTY

In case of the following reasons of the defect, it may void the warranty.
Please refer to the respective warranty condition for details which varies from different countries.

1. The product is not used in accordance with the instruction of the owner's manual.
2. The product is repaired or modified by the one who is not an authorized repair service provider.
3. When the product is used with the inapplicable cameras, lens or adaptors or such accessories produced by the third party.
4. Fault or defect caused by fire, earthquake, flood, public pollution and such natural accidents.
5. in the case that the product is stored in dust, moisture, extremely high temperature or such poor conditions.
6. Scratch, blemish, crush or worn out by a violently use or treatment.
7. Guarantee card without the name of place purchased or the date of purchase stamped, or no guarantee card.